

LC-50

Integrated Gas Mixer, Throttle Body, and Programmable Speed Control/Actuator

Application

The LC-50 is designed for use on gaseous fueled industrial engines between 5 and 100 kW (7 and 134 hp). The throttle and venturi sizes are between 24 and 50 mm.

Applications include power generation, refrigeration units, pumps, irrigation, and mobile industrial.

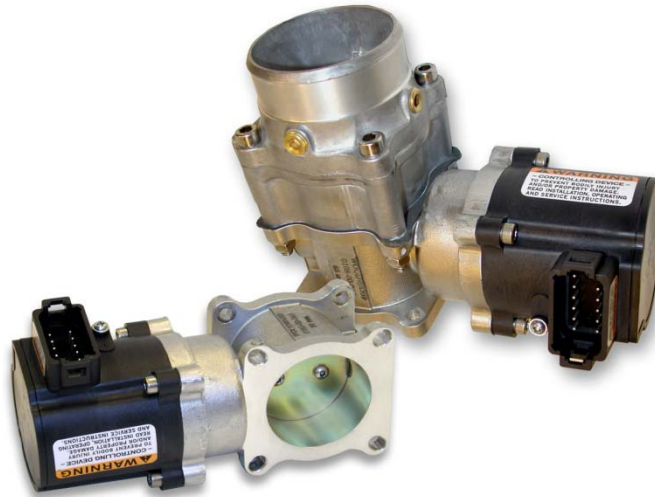

The mixer can be used with propane and natural gas and requires a zero pressure regulator. The throttle body incorporates the proven Woodward L-Series speed control, which operates the throttle plate. The LC-50 can be programmed via the RS-232 port of a PC/laptop to a variety of configurations, as follows:

- isochronous speed control
- auxiliary input
- adjustable ramp time
- remote speed setting
- error relay driver
- droop
- dual dynamics
- overspeed/underspeed protection
- three speed select

Description

The LC-50 provides a building block approach to total engine management. This modular design consists of a die-cast aluminum throttle body, mixer, plus a fully programmable integrated digital speed control and bi-directional actuator.

This unique design includes a venturi style annular ring mixer with no moving parts for superior mixing. The throttle body incorporates a corrosion-protected, plated steel shaft, plate, and an optional sealed ball-bearing design for durability and long life. An internal throttle return spring is standard to close the throttle in the event of power failure.

The LC-50 modular design reduces total engine assembly cost, eliminates external linkages, lowers inventory and part number proliferation. The programmable controller offers security to your configuration.

The LC-50 is compatible with Woodward's venturi-style mixer and other brands of gas mixers using suitable adapters (see L-Series product specification 03225 for actuator details and operating parameters).

- Integrated, bi-directional actuator and programmable speed control
- Suitable for gaseous engines
- OEM configurable
- Venturi mixer has superior mixing with no moving parts
- Eliminates external linkages
- Reduces total engine assembly costs
- Optional positioner mode
- Five sizes available
- Optional air/fuel ratio trim valve
- Optional sealed ball-bearing throttle body design
- Optional external throttle position switch

Specifications

Mass/Weight	425 g (15 oz)
Engine Type	2-cycle or 4-cycle gasoline, diesel, or gaseous fuel
Actuator Torque	High-efficiency torque motor delivers 0.34 N·m (0.25 lb-ft) (standard model) over 60° travel range to operate fuel or air control

Environment

Ambient Operating Temperature	-40 to +105 °C (-40 to +221 °F)
Storage Temperature	-40 to +125 °C (-40 to +257 °F)
Humidity	US MIL-STD 810E, Method 507.3, Procedure III
Salt Spray	US MIL-STD 810E, Method 509.3, Procedure I
Shock	MS1-40G 11ms sawtooth
Vibration	Random: 0.3 G ² /Hz, 10–2000 Hz (22.1Grms) 3 h/axis Sine: 5 G 2.5 mm peak-to-peak, 5–2000 Hz, 3 h/axis, 90 min dwells, 1 octave/min
Drop	SAE J1211, Paragraph 4.8.3 (modified)
Thermal Shock	SAE J1455, Paragraph 4.1.3.2
Ingress Protection	IP56 per EN60529
Inlet Pressure	Sealed shaft bearings: 2 bar (29 psi) gage Standard shaft bearings: 0.068 bar (1 psi) gage

Reliability and Quality Goals

The L-Series control system has a reliability target of 17 500 hours MTBF. It also has a quality goal of less than 25 PPM when measuring out-of-the-box defects. This quality goal is a target based on continuous improvement.

Technical Manual 26249

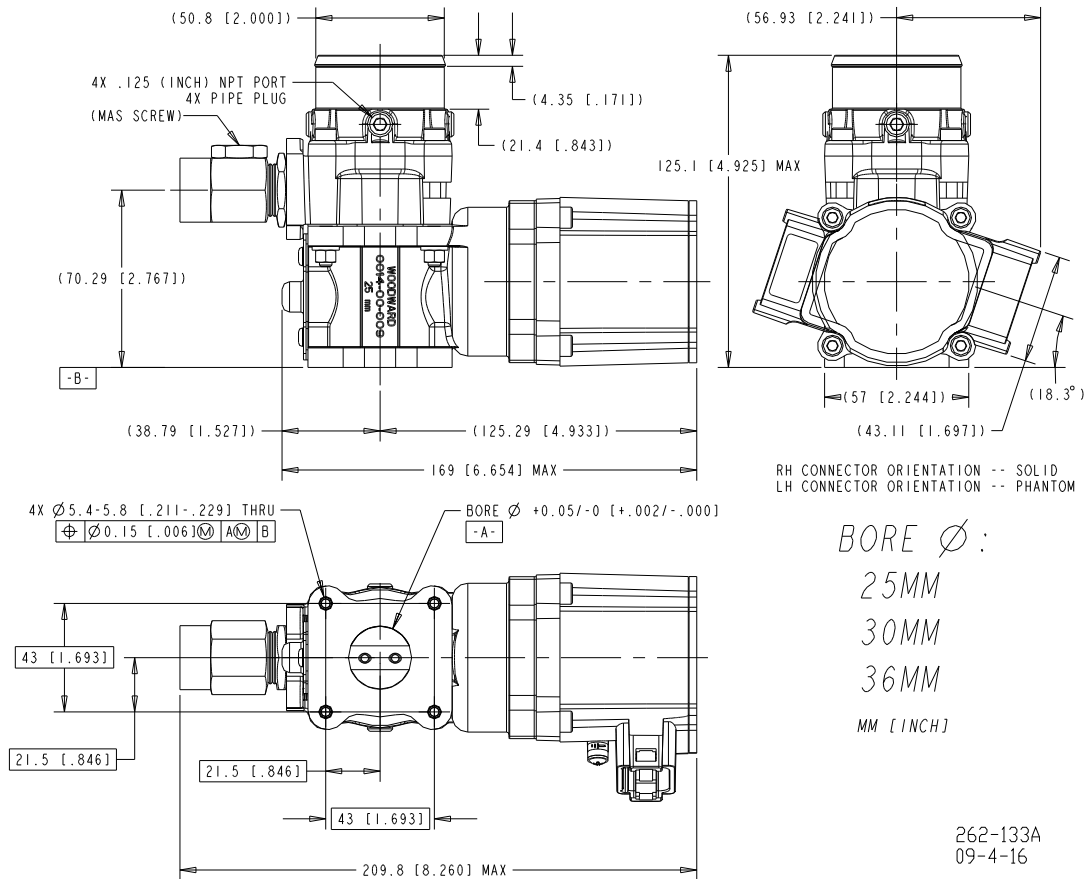

Representative Drawing of LC-50 (small-bore shown) (Do not use for construction)



PO Box 1519, Fort Collins CO, USA 80522-1519
1000 East Drake Road, Fort Collins CO 80525
Tel.: +1 (970) 482-5811 • Fax: +1 (970) 498-3058
www.woodward.com

Distributors & Service

Woodward has an international network of distributors and service facilities. For your nearest representative, call the Fort Collins plant or see the Worldwide Directory on our website.

This document is distributed for informational purposes only. It is not to be construed as creating or becoming part of any Woodward Governor Company contractual or warranty obligation unless expressly stated in a written sales contract.

© Woodward 2000, All Rights Reserved

For more information contact:

2009/12/Fort Collins