

2301D-ST

Digital Load Sharing and Speed Control



Applications

The 2301D-ST is a field-configurable control designed for single-valve steam turbine applications. This control is configurable to allow it to be easily applied in a diverse range of turbine applications.

The control can be configured as a replacement for Woodward 2301A or 2301A LSSC controls, or for use within new turbine applications.

The 2301D-ST includes the following basic turbine control functions:

- Speed Control
- Start Valve Ramp
- Overspeed Protection
- Shutdown Logic
- Alarm Logic
- Platform Diagnostics
- Manual Start, Semi-Automatic Start, Automatic Start option
- Self Powered Actuator option

Alternatively, the following functions can be configured, depending on application requirements (I/O limitations may prohibit selecting all listed functions at once):

- Process control
- Critical Speed Avoidance logic
- Remote Speed/Load setpoint
- Droop/Isoch Control
- KW/Actuator Droop
- Load Sharing (with soft load/unload transfer)
- SPM-A (Synchronizer) Input
- Power Sensor Input (PTs & CTs)
- ServLink (DDE)/Modbus® * Communications

An integral RS-232 communications port allows users to interface with the 2301D-ST through industry-standard Dynamic Data Exchange (DDE) or Modbus based protocols. Alternatively a contact can be programmed to allow users to switch between protocols as desired.

A hazardous location version is available.

*—Modbus is a trademark of Schneider Automation Inc.

- Single-valve small steam turbine applications
- Process control capability
- Load sharing and speed control
- Droop, kW droop, and isochronous control capability
- Soft load transfer
- Remote setpoint
- Critical speed avoidance
- PC configurable with Woodward Watch Window software
- Designed for 300–32 000 rpm applications
- Actuator current range of 4–20 mA or 20–200 mA
- 2301A replacement
- Modbus® serial communications

Description

The Woodward 2301D-ST is a microprocessor based control with integral application software designed for single-valve steam turbine applications. Like Woodward's 2301A line of controls, this control is housed in a sheet-metal chassis and consists of a single printed circuit board. To facilitate unit retrofits, the 2301D-ST's I/O terminals are located in the same general location as Woodward's 2301A line of controls.

This control is designed to perform the core control functions of a small steam turbine package. The application software is field configurable, allowing it to be configured and modified to meet site-specific requirements.

With more I/O than its predecessor (the 2301A LSSC), the 2301D-ST control also has serial communications, allowing it to easily interface with the package PLC or plant DCS.

The 2301D-ST is configured and serviced (dynamic adjustments made) via a laptop computer connected to the control's RS-232 communications port. These configuration and dynamic settings are set, changed, tuned, and saved via a laptop computer and Woodward's user-friendly Watch Window software program. This Windows[®] based PC program allows users to set and adjust all application-based parameters, plus upload and download configurations to and from the control.

Control Functions

The Woodward 2301D-ST controls a wide variety of single-valve steam turbines used in electrical generator, compressor drive, or pump applications.

Turbine Start-up/Shutdown

The 2301D-ST provides configurable turbine start-up scheduling via a Valve Ramp. On start-up, the turbine accelerates according to the Valve Ramp schedule until the speed control loop takes control of the turbine. The valve ramp can also be used to shutdown the turbine.

Isoch/Droop Operation

When configured for generator drive applications, the 2301D-ST can operate in either an isochronous or droop load mode. In the "Isoch" mode, the 2301D-ST controls plant/unit frequency control by maintaining turbine speed. In the "Droop" mode the 2301D-ST controls generator load. If the generator is connected to the utility bus while in droop mode, the unit speed will be determined entirely by the bus frequency. If the generator is disconnected from the utility bus, the unit speed will "droop" as the load increases.

KW Droop Operation

If KW droop is configured, the control uses the output from its integral power sensor to sense and control unit load. The control's power sensor output can be monitored via serial communications or through the control's analog readout. If required, any of the control's four relay outputs can be configured as a power level switch to drive auxiliary devices or indicators.

Isochronous Load Sharing

The 2301D-ST includes an analog load sharing network input, which is compatible with Woodward's 2301A line of controls. The control's soft load/unload transfer function can also be configured to rate limit unit loading and unloading.

SPM-A Input

Optionally the 2301D-ST can be configured to accept a ± 3 Vdc synchronizing signal. This input is compatible with and intended to be used in conjunction with Woodward's SPM-A synchronizers.

Critical Speed Avoidance

The 2301D-ST can be configured to provide one speed range to be avoided for turbine protection. Under normal circumstances, the turbine speed setpoint will rapidly ramp through the critical speed range.

Remote Speed Setpoint

One of the analog inputs can be configured to remotely control the speed setpoint. The maximum rate at which the speed setpoint can be changed by the remote input is configurable by the user. The remote speed setpoint is enabled and disabled from a contact input or Modbus communications.

Process Control

A process control can be configured to receive a remote process input. That process input is compared to a process setpoint to maintain the desired process operating point. The process setpoint is adjustable by raise/lower contact inputs, Modbus communications or a configurable remote 4–20 mA setpoint signal.

Communications

The 2301D-ST's RS-232 port serves two purposes: to configure and service the control, and to interface with the control through Modbus communications. A Windows based PC program used on a control-connected laptop is used to set and adjust all application-based parameters, plus upload and download configurations to and from the control. Once the control has been configured, an optional switch can be used to select ports Modbus protocol. Through Modbus communications, a user can monitor all turbine-specific parameters as well as control the unit (start, stop, etc.) as desired.

Specifications

Woodward Part Numbers:

8273-128
8273-1001
8923-932

2301D-ST Digital Load Sharing and Speed Control, 24 Vdc input
Hazardous location 2301D-ST Digital Load Sharing and Speed Control, 24 Vdc input
Watch Window Installation

Power Supply Rating 18–40 Vdc (SELV)
Power Consumption less than or equal 20 W nominal

Input Supply Voltage 18 V
24 V (nominal)
32 V
Input Supply Current (typical)
590 mA
430 mA
320 mA

Inrush Current 7 A for 0.1 ms (24 Vdc input)
Steady State Speed Band ±0.25% of rated speed
Magnetic Pickup 100–24,950 Hz
Discrete Inputs (8) 3 mA at 24 Vdc, impedance approximately 5.2 kΩ
Analog Inputs (2) 4–20 mA
Actuator Output 4–20 or 20–200 mA to actuator, software configurable
Analog Output 4–20 mA, internally powered
Discrete Outputs (4) configurable relay drivers, powered by external +12 or +24 Vdc source, max output current 200 mA

Communication Port RS-232, 9-pin connector, 1200 to 38,400 baud, full duplex
Ambient Operating Temperature –40 to +70 °C (–40 to +158 °F)
Storage Temperature –40 to +105 °C (–40 to +221 °F)
Humidity 95% at +20 to +55 °C (+68 to +131 °F)

Mechanical Vibration Lloyd's Register of Shipping Specification Humidity Test 1
Mechanical Shock Lloyd's Register of Shipping Specification Vibration Test 2
US MIL-STD 810C, Method 516.2, Procedure I (basic design test), Procedure II (transit drop test, packaged), Procedure V (bench handling)
Equipment Classification Class 1 (grounded equipment)

Technical Manual 26184

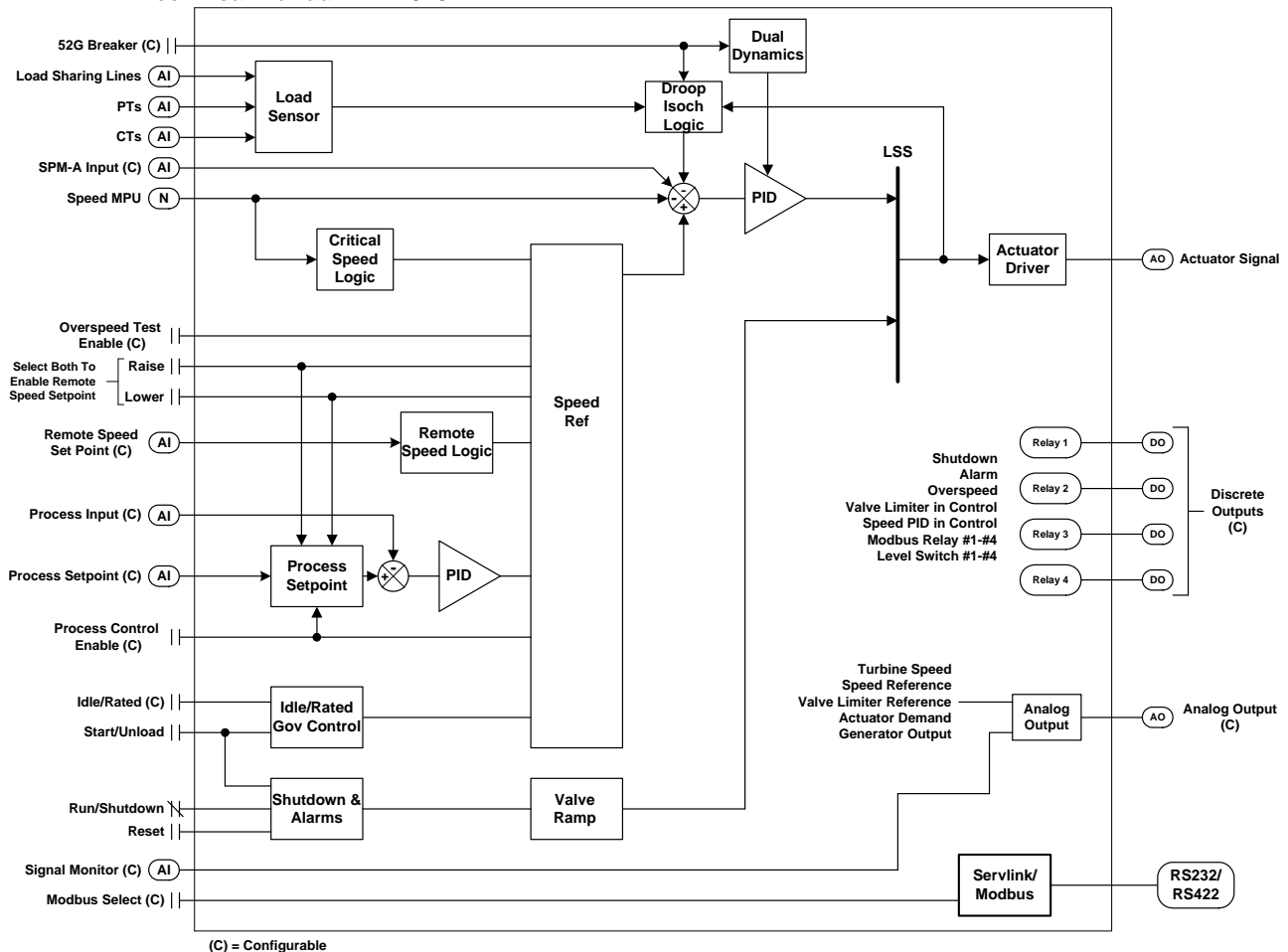

2301D-ST Digital Control Block Diagram

Configurability

The configurability of the 2301D-ST's application software allows such parameters as turbine speed range, gear teeth, and analog I/O functionality, discrete I/O functionality, internal control limits, and actuator output current to be configured off-line and with certain parameters on-line.

Input Signals

Discrete Inputs (8)

Five discrete inputs (D) are assigned predefined functions, and three discrete inputs are configurable (P):

- External Shutdown (D)
- System Reset (D)
- Start/Unload Command (D)
- Speed Raise (D) or Process Raise (D)
- Speed Lower (D) or Process Lower (D)
- 52-fG–Gen Breaker (P)
- Idle/Rate Switch (P)
- Modbus Enable (P)
- Overspeed Test Enable (P)
- Process Control Enable (P)

Speed Signal (1)

- One magnetic pickup speed signal (300–32 000 rpm)

Analog Inputs (2)

Two Analog Inputs configurable to accept:

- SPM-A (Synchronizer, ± 3 Vdc)
- Remote Speed Setpoint Signal
- External Analog Input (for relay switching and/or Modbus monitoring)
- Remote Process Variable
- Remote Process Setpoint

Load Sensor Inputs

- Generator PT Signals
- Generator CT Signals

Load Sharing

- Load Sharing Lines

Output Signals

Discrete Outputs (4)

All discrete outputs can be configured for:

- Shutdown
- Alarm
- Overspeed Test Alarm
- Valve Limiter in Control
- Speed PID in Control
- Process PID in Control
- Modbus Controlled Relay #1
- Modbus Controlled Relay #2
- Modbus Controlled Relay #3
- Modbus Controlled Relay #4
- Level Switch
 - Actual Speed
 - Speed Reference
 - Valve Limiter Reference
 - Actuator Demand
 - Generator Output
 - Signal Monitor

Actuator Signal Output (1)

- One actuator driver (4–20 mA/20–200 mA)

Analog Outputs (1)

One analog output can be configured for:

- Turbine Speed
- Speed Setpoint
- Valve Limiter Setpoint
- Actuator Demand
- Generator Load
- Signal Monitor

Regulatory Compliance

European Compliance for CE Mark:

EMC Directive	Certified to 89/336/EEC COUNCIL DIRECTIVE of 03 May 1989 on the approximation of the laws of the member states relating to electromagnetic compatibility.
Low Voltage Directive	Certified to the 73/23/EEC COUNCIL DIRECTIVE of 19 February 1973 on the harmonization of the laws of the Member States relating to electrical equipment designed for use within certain voltage limits.

North American Compliance:

CSA	CSA Certified for Ordinary Locations for use in the United States and Canada.
CSA	CSA Certified for use in Class I, Division 2, Groups A, B, C, D in the United States and Canada.
NOTE	Wiring must be in accordance with applicable electric codes with the authority having jurisdiction.

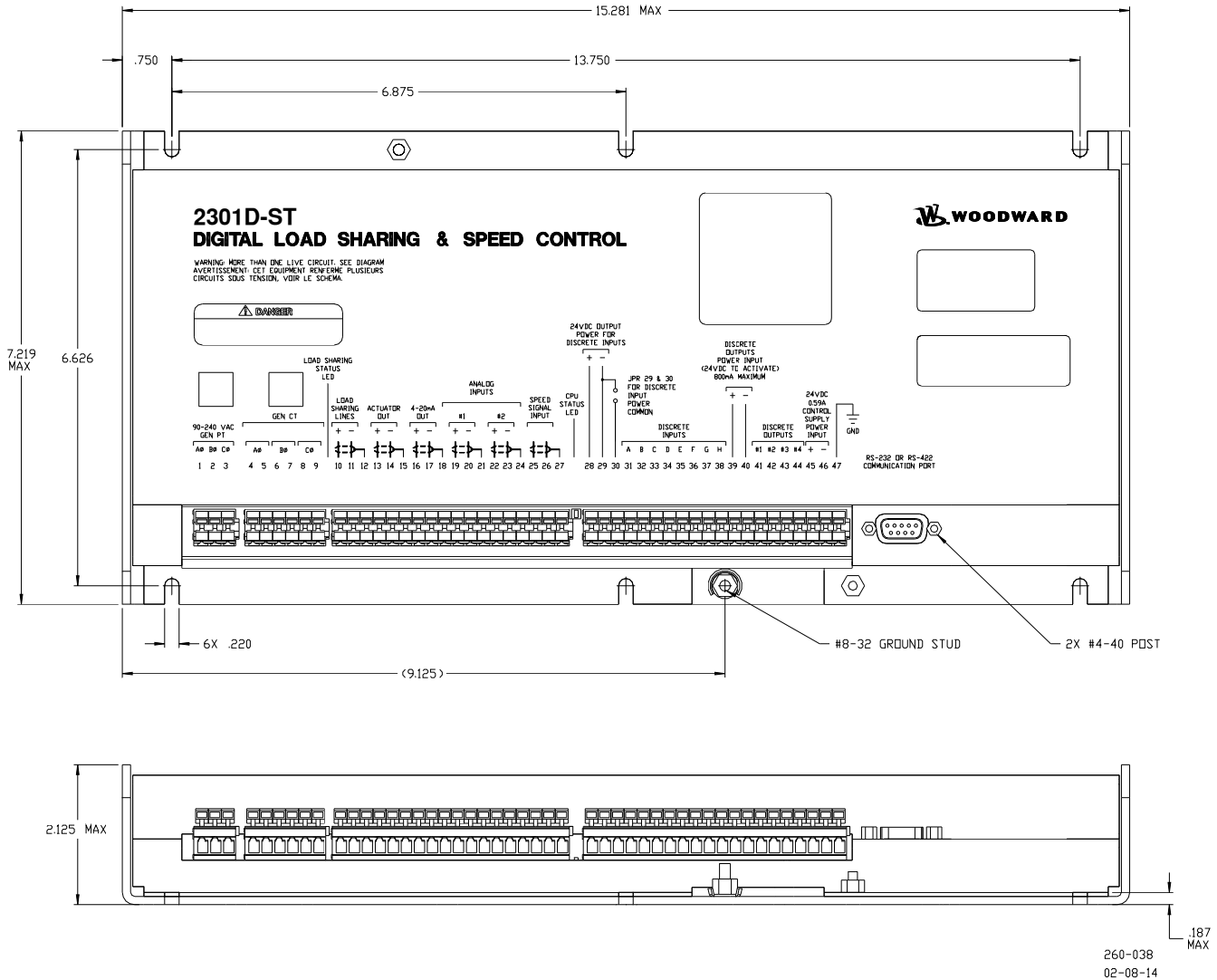

2301D-ST Digital Control Outline Drawing (standard version)
 (Do not use for construction)



PO Box 1519, Fort Collins CO, USA 80522-1519
 1000 East Drake Road, Fort Collins CO 80525
 Tel.: +1 (970) 482-5811 • Fax: +1 (970) 498-3058
www.woodward.com

Distributors & Service

Woodward has an international network of distributors and service facilities. For your nearest representative, call the Fort Collins plant or see the Worldwide Directory on our website.

This document is distributed for informational purposes only. It is not to be construed as creating or becoming part of any Woodward Governor Company contractual or warranty obligation unless expressly stated in a written sales contract.

© Woodward 2002, All Rights Reserved

For more information contact:

2010/8/Colorado